

Remote Pressure Balancing Valve

Installation Instructions

Description

The "In-Line" remote pressure balancing valve protects another plumbing fixture from dangerous outlet temperature changes that can result from fluctuating inlet pressures. This unit automatically adjusts the hot and cold inlet pressures in order to maintain a constant temperature. If either the hot or cold water supply fails for any reason, the remote pressure balancing valve will go into its anti-scald mode and safely reduce the flow of water to a mere trickle, until both hot and cold water supplies are fully restored.

This product is precision engineered to provide satisfactory performance provided it is installed and operated in accordance with the recommendations contained in this installation and service manual. In order to fully enjoy the comfort, safety and reliability of your "In-Line" remote pressure balancing valve, please be certain to familiarize yourself with the contents of this installation and service manual.

Specifications and Dimensions

| | | |
|--------------------------------|---------------|------------|
| Min. operating pressure: | 20 psi | [140 KPa] |
| Max. operating pressure: | 125 psi | [860 KPa] |
| Max. test pressure: | 500 psi | [3450 KPa] |
| Max. hot water temperature: | 180° F | / 80°C |
| Hot and cold inlets / outlets: | ½" female NPT | |

Installation

NOTE: Failure to follow these instructions may cause damage or improper operation may void the warranty.

1. Select a location to provide for service access of the pressure balancing valve after installation.
2. Connect the water supplies to the pressure balancing valve side inlets, either side inlet can be used for hot or cold water connection.

Caution: Use only propane or butane gas when soldering, **(Do not use oxygen/acetylene)**, as extreme heat may damage internal components.

3. If required, optional service stops can be fitted to side inlets of the pressure balancing valve.
4. Connect the outlets of the pressure balancing valve to the fixture you wish to be protected (only one fixture per RPB valve).

Important: In order for the pressure balancing Valve to function safely and correctly. The hot and cold outlets must always match up with the hot and cold inlets.

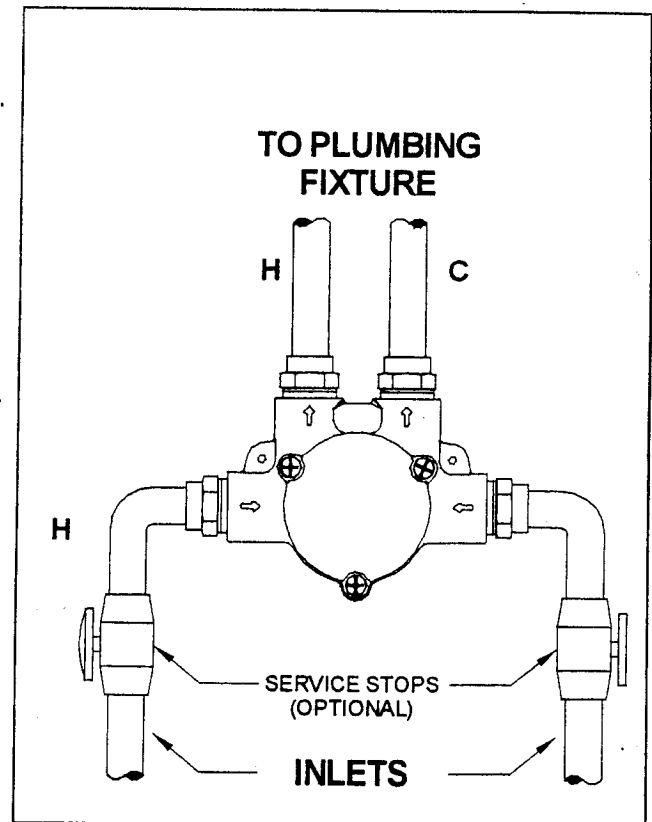
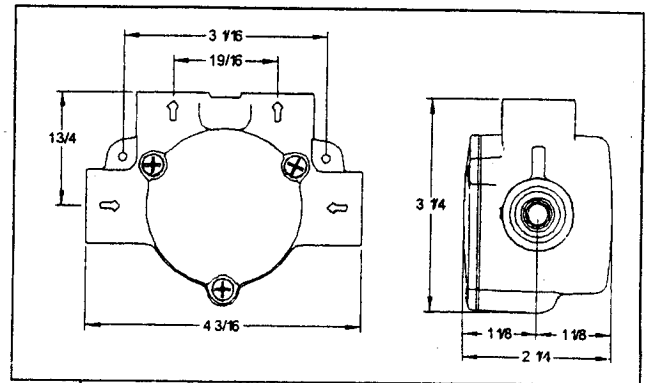

Testing and trouble shooting

To test and operate the "In-Line" remote pressure balancing valve, it is necessary for both hot and cold water supply lines to the valve are pressurized.

If there is no flow of hot or cold water from the fixture you have connected to the remote pressure balancing valve. Check that both the main hot and cold water supplies and the service stops (if used) are fully open and pressurized.

If there is still no flow of water, shut off both hot and cold water supplies or service stops (if used) to the pressure balancing valve. Remove pressure balancing valve cover, cartridge and check inserts. **Warning, water in downstream pipes will run out when the cartridge is removed.** Inspect cartridge and check inserts for possible in-line debris, if present, flush out cartridge and check inserts. Check that all O-rings on the check inserts, cartridge and valve cover are intact, clean and free of any dirt or particles. Fit check inserts into valve body with beveled edge facing towards front of valve body. Slide cartridge all the way into the valve body with the 2 cartridge outlet O-rings aligned with the valve body outlets. Fit valve cover and tighten the 3 screws firmly. Open both hot and cold water supplies or service stops (if used) and test the fixture you have connected to the remote pressure balancing valve.

This valve is designed for a minimum of maintenance in normal use. If a malfunction occurs, this necessitates a complete cartridge and or check insert kit replacement. The cartridge or check inserts do not have any internally serviceable parts. If replacement parts are required, contact your installer or dealer and be sure to specify cartridge or check insert kit for the Tempress "In-Line" remote pressure balancing valve RPB 2

Replacement parts

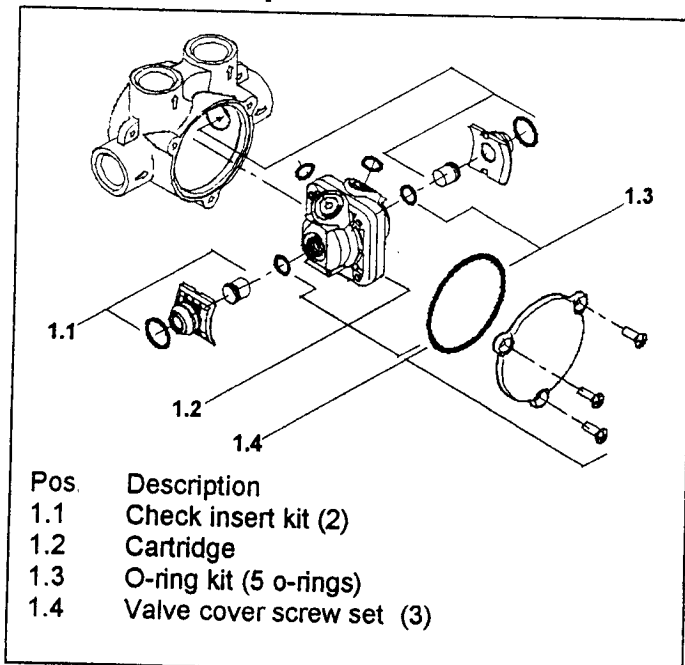

Flow Rate

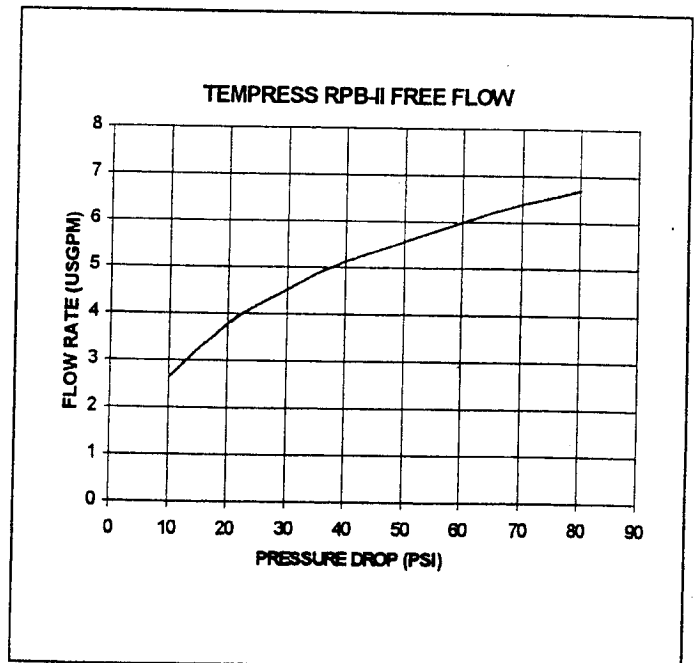

Sign of  the Crab

3756 Omec Circle
Rancho Cordova, CA 95742